

Snake



Snake



Les nacelles articulées Snake sont disponibles aujourd'hui avec pantographe simple ou double qui permet d'enjamber l'obstacle en hauteur

TRES GRANDE COMPACTITÉ: les plateformes aériennes Snake se distinguent des autres constructeurs par l'encombrement réduit du porteur en marche.

STABILISATION: les séries Snake peuvent être stabilisées dans des espaces réduits et grâce aux dispositifs de sécurité dont elles sont dotées, elles assurent une plus grande sécurité à l'opérateur.

ENJAMBEMENT: une qualité fondamentale de la série Snake est celle de permettre à l'opérateur de travailler dans la plus grande simplicité et sécurité de départ, par exemple un pont ou un obstacle quelconque empêchant de stabiliser la plateforme le plus près possible du lieu de travail.



Die Scherenbühnen Snake sind ab heute mit ein- oder zweifachem Pantografen lieferbar, der der Maschine die Fähigkeit verleiht, die Klappgelenke des Arbeitsarms höher zu heben und daher Hindernisse in der Höhe zu überwinden.

HÖCHSTE KOMPAKTHEIT: Die Hubarbeitsbühnen Snake unterscheiden sich von denen anderer Hersteller durch die geringeren Ausmaße des Lastwagens in Fahrt.

STABILISIERUNG: Die Modelle der Reihe Snake können auf kleinem Raum stabilisiert werden und dank der Sicherheitsvorrichtungen, mit denen sie ausgestattet sind, eine maximale Sicherheit des Bedieners gewährleisten.

ÜBERSTEIFEN: Eine wesentliche Eigenschaft der Reihe Snake ist die, den Bediener beispielsweise nach dem Übersteigen einer Brücke oder irgendeines Hindernisses, die eine Stabilisierung der Plattform näher am Arbeitsplatz unmöglich machen, in höchster Einfachheit und Sicherheit arbeiten zu lassen.

Snake 2190 "Metropolis" ist die einzige Arbeitsbühne für Führerscheinklasse B mit zweifachem Gelenk, das eine Übersteighöhe von 10.5 m ermöglicht.

Der in der Luft befindliche Teil ist frei von Begrenzungsvorrichtungen, was dieses Modell ideal für den Verleih macht.



Le piattaforme articolate della serie Snake sono disponibili con pantografo semplice o doppio che conferisce alla macchina la capacità di elevare in quota la cerniera di articolazione del braccio di lavoro e quindi di scavalcare ostacoli in quota.

MASSIMA COMPATTEZZA: le piattaforme aeree Snake si distinguono da quelle di altri produttori per i più ridotti ingombri dell'autocarro in marcia.

STABILIZZAZIONE: le serie Snake possono essere stabilizzate in spazi ristretti e, grazie ai dispositivi di sicurezza di cui sono dotate, assicurare la massima sicurezza all'operatore.

SCAVALCAMENTO: una qualità fondamentale della serie Snake è quella di permettere all'operatore di lavorare in massima semplicità e sicurezza oltrepassato ad esempio un ponte od un qualsiasi ostacolo che impedisca di stabilizzare la piattaforma più vicina al luogo dove si deve operare.



Snake articulated platforms are now available with simple or double pantograph, which allows the machine to lift the articulation hinge of the working arm over high obstacles.

HIGHLY COMPACT: Snake aerial platforms stand out from those of other manufacturers for the smaller size of the moving truck.

STABILISATION: Snake series can be stabilised in narrow spaces and, thanks to its safety devices, ensures the operator the highest safety.

CROSSING: a basic feature of the Snake series is allowing the operator to work safely and easily over a bridge or any obstacle that prevents the platform from being stabilised closer to the place of intervention.



Snake 189 SMART - 2112 SMART



1

Stabilizzatori
Stabiliser
Stabilisateur
Stabilisator
Estabilizador
Stempelpoten
Støtteben



4

Comandi per la stabilizzazione in basso
Low stabilisation controls
Commandes pour stabilisation en bas
Notsteuerungen unten
Comandos para la estabilización en la parte inferior
Bediening voor de stempelpoten
Lavtsiddende støttebensbetjening)



5

Carter e comandi sopra cestello
Sumps and high controls on cage
Carter et commandes sur panier
Steuerung am Arbeitskorb
Carter y comandos arriba de la cesta
Bediening in basket
Plattformkontrolpanel



2

Carter e comandi di emergenza in basso
Sumpa and low emergency controls
Carter et commandes d'urgence en bas
Notsteuerungen unten
Carter y comandos de emergencia en la parte inferior
Noodbediening beneden
Nødbetjening fra jordniveau



3

Pompa per discesa di emergenza
Manual pump for emergency descent
Pompe à main pour descente d'urgence
Manual pump for emergency descent
Von Hand betriebene Pumpe zum Notabsenken
hand pomp voor nooddaling
Håndpumpe for nødbetjening
Bomba de mano para descenso de emergencia



Snake 2112 SMART

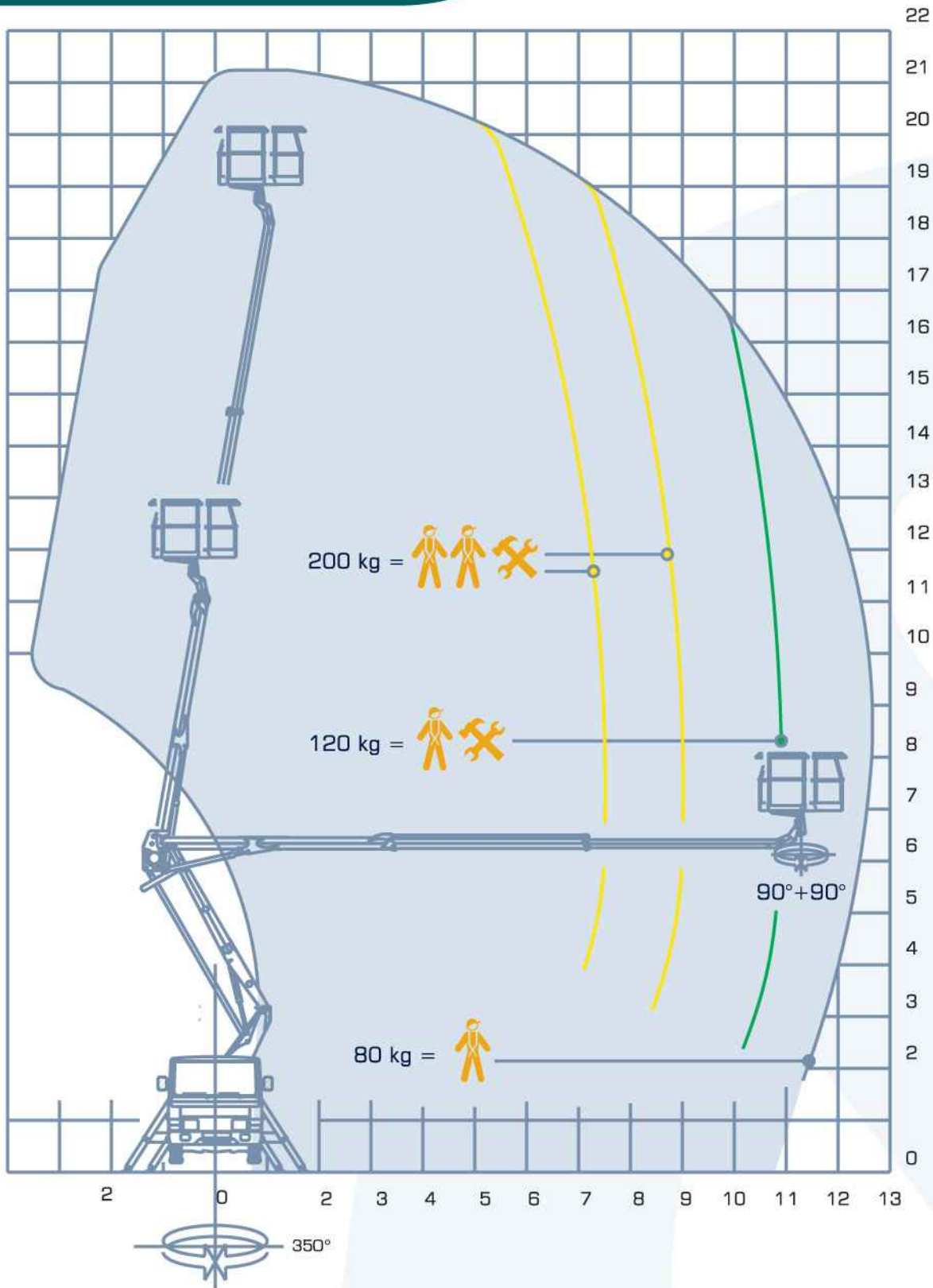

La Snake 2112 SMART è capace di un'altezza massima di lavoro di ben 21 m e di uno sbraccio laterale pari a 12 m.

The Snake 2112 SMART features a working height of 19 m and a lateral range of 11 m.

La Snake 2112 SMART peut atteindre une hauteur maximum de travail de 21 m et sa portée latérale est égale à 12 m.

Die Snake 2112 hat eine maximale Arbeitshöhe von 21 m und eine seitliche Reichweite von 12 m.

El modelo Snake 2112 SMART puede alcanzar una altura máxima de trabajo de 21 m y un alcance lateral de 12 m.

Snake 2112 autohoogwerker heeft een werkhogte van 21 meter en een werkbereik van 12 meter.

Snake 2112 har en arbejdsøjde på 21 m samt et horisontalt udlæg på 12 m.

- 200 kg =
- 120 kg =
- 80 kg =

**DATI TECNICI - SPECIFICATION CARACTERISTIQUES
TECHNIQUES - TECHNISCHE DATEN - DATOS
TÉCNICOS TECHNISCHE SPECIFICATIES -
SPECIFIKATIONER**



21 m



19 m



12 m



Doppia barra, in acciaio - Double bar, steel
Barre double, en acier - Doppelbarren,
stahl - Double barra, en acero
Dubbel gelaagd staal - Dobbelt bar, stål



360°
(non continua) - (not continuous)
(not continue) - (nicht kontinuierlich)
(no continua) - (niet continu)
(ikke kontinuierlig)



1400x700xh 1100 mm
(alluminio) - (aluminium) - (aluminium)
(alu) - (aluminio) - (aluminium) - (aluminium)



Idraulica 90° dx + 90° sx- Hydraulic 90° right + 90° left
Hydraulique 90° droite + 90° gauche
Hidráulica 90° derecha + 90° izquierda hidráulisch 90°
re + 90° li - Hydraulisch 90° rechts + 90° links
Hydraulisk 90° højre+ 90° venstre



Tipo idraulici proporzionali - Proportional hydraulic type
Hydrauliques proportionnelles - Tipo hidráulico proporcional
Hydraulisch proportional - Proportioneel hydraulisch
type - Proportional hydraulisk type



120-200 kg / 1-2
Operatori - Operators - Operateurs
Operarios - Bediener - Personen
Operatører



3000 mm



6160 mm



2100 mm



Tipo ad a su traverse estensibili
Type a on extensible supports
Type a sur traverses extensibles
Tipo a sobre soportes extensibles
Typ a extensible - Type a - Type a udskydelig



3,5 Ton

Snake 2112 SMART

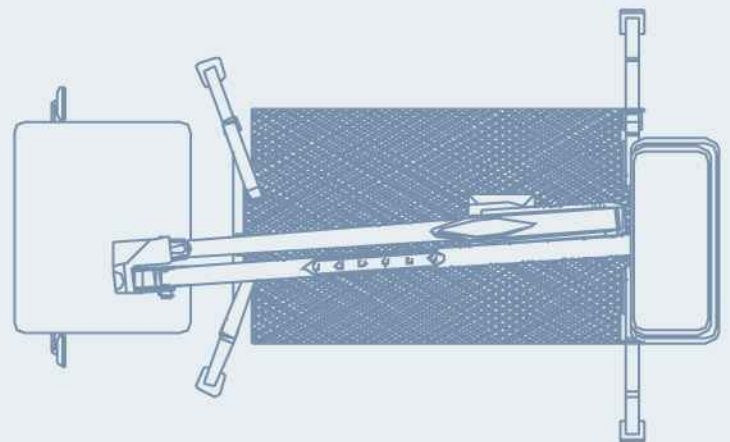
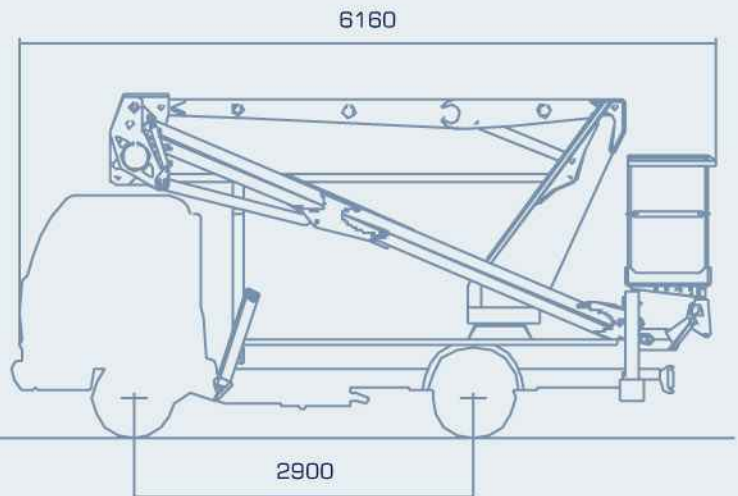
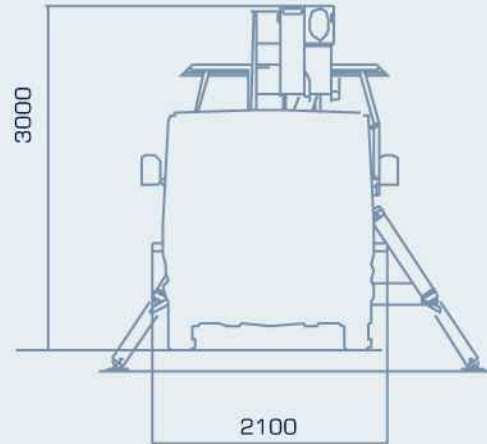

OIL & STEEL